

---

*Control de Procesos Químicos*

## **Tema 5 – Representación**

Diagramas de tuberías e instrumentos  
Diagramas lógicos de control

The logo for Cartagena99 features the text 'Cartagena99' in a stylized, green, cursive font. The text is positioned above a blue and orange graphic element that resembles a stylized map of the city of Cartagena, with a blue area on the left and an orange area on the right.

CLASES PARTICULARES, TUTORÍAS TÉCNICAS ONLINE  
LLAMA O ENVÍA WHATSAPP: 689 45 44 70

---

ONLINE PRIVATE LESSONS FOR SCIENCE STUDENTS  
CALL OR WHATSAPP:689 45 44 70

# Representación

**P&I** (Piping and Instrumentation) representan al proceso, las operaciones unitarias de procesos y el sistema de control implementado sobre el mismo. En éste se incluyen:
 

- Instrumentos de medida
- Controladores que implementan la estrategia de control
- Alimentación que proporcionan la lógica de control
- Normas específicas de representación de equipos e instrumentos.

 Norma Internacional para la Medición y el Control Instrumental  
 Asociación Internacional de Fabricantes de Aparatos Científicos

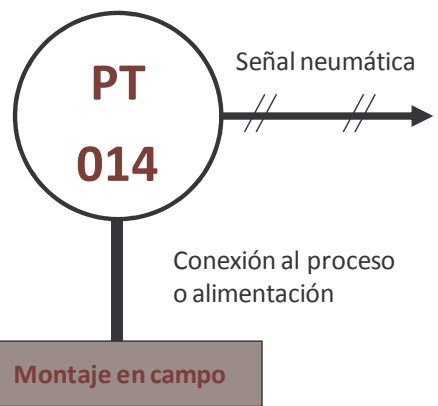
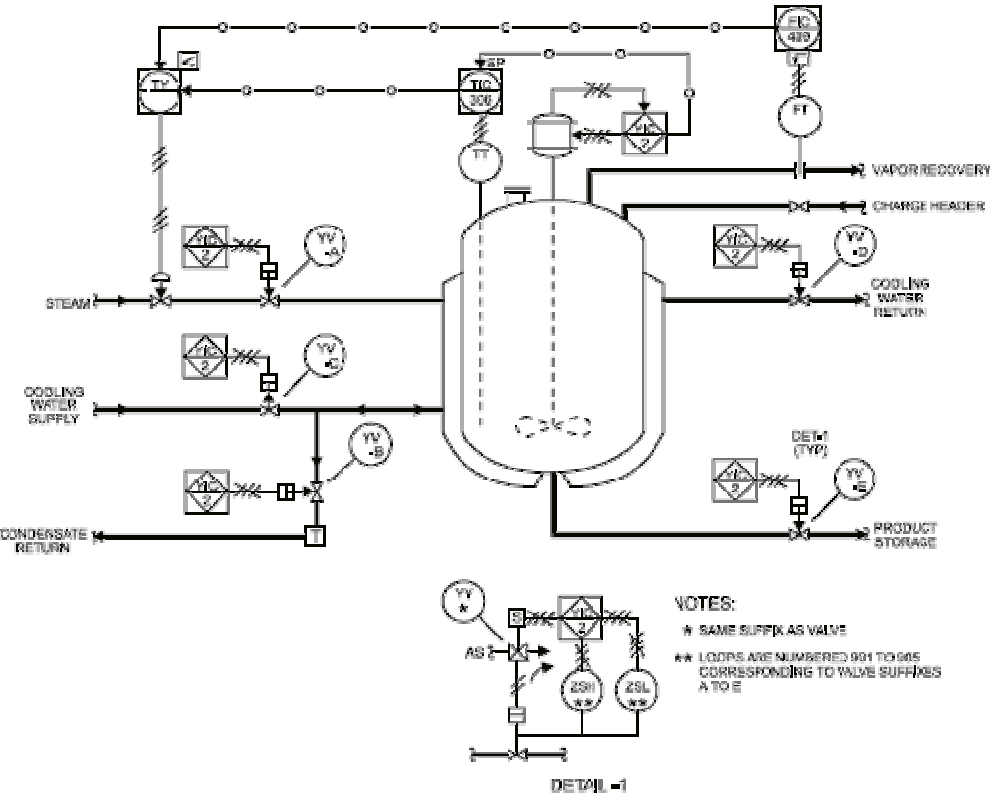

Indican la variable leída, manipulada y la acción que se realiza. El número es el identificador de los instrumentos de un sistema de regulación.



CLASES PARTICULARES, TUTORÍAS TÉCNICAS ONLINE  
 LLAMA O ENVÍA WHATSAPP: 689 45 44 70  
 ---  
 ONLINE PRIVATE LESSONS FOR SCIENCE STUDENTS  
 CALL OR WHATSAPP: 689 45 44 70

## Representación

&l

análisis  
densidad  
voltaje  
caudal  
corriente  
potencia  
nivel  
humedad  
presión  
velocidad  
temperatura  
viscosidad  
Peso  
posición

1ª letra: **Variable medida o relacionada**

2ª letra: **Puede cualificar a la primera**

D	diferencial
F	relación
S	seguridad
Q	integración

3ª y sig: **Función del Instrumento**

I	indicador
R	registro
C	control
T	transmisor
V	válvula
Y	cálculo
H	alto
L	bajo



CLASES PARTICULARES, TUTORÍAS TÉCNICAS ONLINE  
LLAMA O ENVÍA WHATSAPP: 689 45 44 70

---

ONLINE PRIVATE LESSONS FOR SCIENCE STUDENTS  
CALL OR WHATSAPP:689 45 44 70

## Representación

<u>1ª LETRA:</u> VARIABLE O ACTUACIÓN	<u>2ª LETRA:</u> TIPO DE LECTURA U OTRA FUNCIÓN	<u>3ª LETRA:</u> FUNCIÓN ADICIONAL
	ALARMA	ALARMA
CONDUCTIVIDAD	REGULACIÓN AUTOMÁTICA	REGULACIÓN AUTOMÁTICA
DENSIDAD		
	ELEMENTO PRIMARIO	
CAUDAL		
	VIDRIO	
ACTUADO A MANO		
	INDICACIÓN	
NIVEL		
HUMEDAD		
PRESIÓN		
	REGISTRO	
VELOCIDAD	SEGURIDAD	
TEMPERATURA		
VISCOSIDAD		VÁLVULA
PESO	FUNDA PROTECTORA	
POSICIÓN		

&l

CLASES PARTICULARES, TUTORÍAS TÉCNICAS ONLINE  
 LLAMA O ENVÍA WHATSAPP: 689 45 44 70  
 ---  
 ONLINE PRIVATE LESSONS FOR SCIENCE STUDENTS  
 CALL OR WHATSAPP:689 45 44 70

## Representación

	CONTROL				MEDIDA				
	REGISTRADOR	INDICADOR	CIEGO	VÁLVULAS DE REGULACIÓN AUTOACCIONADAS	REGISTRDORES	INDICADORES	VÁLVULAS DE SEGURIDAD	DISPOSITIVOS DE CRISTAL	VAINAS
	TRC	TIC	TC	TCV	TR	TI	TSV		TW
	FRC	FIC	FC	FCV	FR	FI	FSV	FG	
	LRC	LIC	LC	LCV	LR	LI		LG	
	PRC	PIC	PC	PCV	PR	PI	PSV		
	DRC	DIC	DC		DR	DI			
		HIC	HC	HCV					
AD	CRC	CIC	CC		CR	CI			
	SRC	SIC	SC	SCV	SR	SI	SSV		

xi



CLASES PARTICULARES, TUTORÍAS TÉCNICAS ONLINE  
 LLAMA O ENVÍA WHATSAPP: 689 45 44 70  
 ---  
 ONLINE PRIVATE LESSONS FOR SCIENCE STUDENTS  
 CALL OR WHATSAPP:689 45 44 70

# Representación

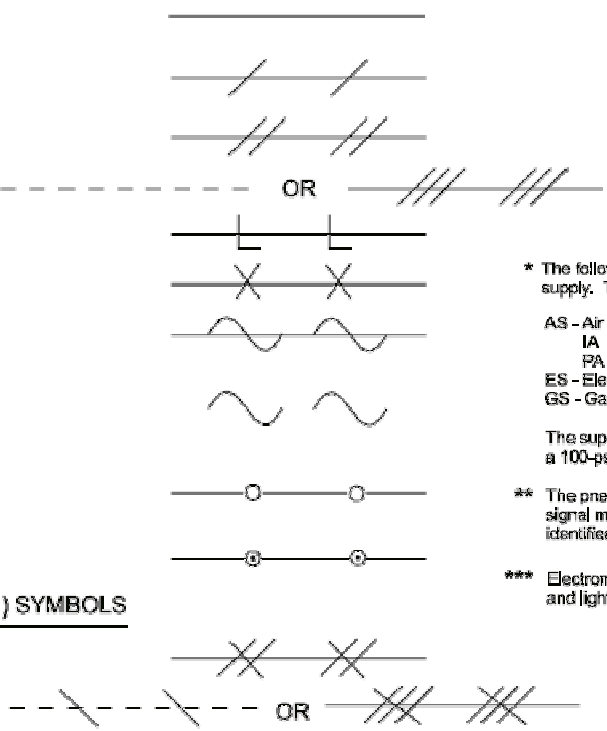

- \* The following abbreviations are suggested to denote the types of power supply. These designations may also be applied to purge fluid supplies.

AS - Air Supply	} Options	HS - Hydraulic Supply
IA - Instrument Air		NS - Nitrogen Supply
PA - Plant Air		SS - Steam Supply
ES - Electric Supply		WS - Water Supply
GS - Gas Supply		

  
- The supply level may be added to the instrument supply line, e.g., AS-100, a 100-psig air supply; ES-24DC, a 24-volt direct current power supply.
- \*\* The pneumatic signal symbol applies to a signal using any gas as the signal medium. If a gas other than air is used, the gas may be identified by a note on the signal symbol or otherwise.
- \*\*\* Electromagnetic phenomena include heat, radio waves, nuclear radiation, and light.

&I

PLY \*  
TO PROCESS

L

L \*\*

L

IC OR SONIC SIGNAL \*\*\*

IC OR SONIC SIGNAL \*\*\*

LINK  
(ATA LINK)

OPTIONAL BINARY ( ON-OFF ) SYMBOLS



Y SIGNAL

SIGNAL





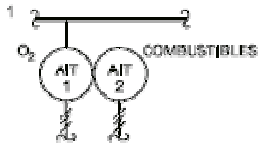

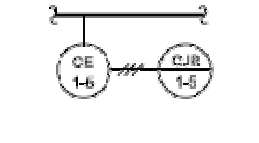
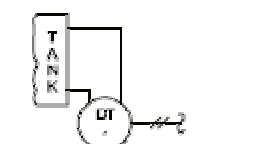
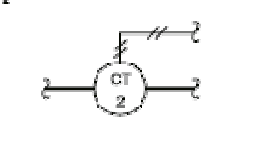
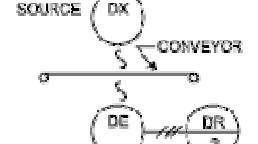







CLASES PARTICULARES, TUTORÍAS TÉCNICAS ONLINE  
 LLAMA O ENVÍA WHATSAPP: 689 45 44 70  
 ---  
 ONLINE PRIVATE LESSONS FOR SCIENCE STUDENTS  
 CALL OR WHATSAPP:689 45 44 70

# Representación

ANALYSIS	1		2	3	
	DUAL ANALYSIS INDICATING TRANSMITTER FOR OXYGEN AND COMBUSTIBLES CONCENTRATIONS				
	BURNER/COMBUSTION	1		2	3
ONE BURNER ULTRAVIOLET FLAME DETECTOR CONNECTED TO ANALOG-TYPE FLAME INTENSITY INDICATOR					
USER'S CHOICE		1		2	3
	CONDUCTIVITY CELL CONNECTED TO POINT 5 OF MULTI-POINT SCANNING CONDUCTIVITY RECORDER				
	USER'S CHOICE	1		2	3
DENSITY TRANSMITTER, DIFFERENTIAL-PRESSURE TYPE, EXTERNALLY CONNECTED					
USER'S CHOICE		1		2	3
	IN-LINE CONSISTENCY TRANSMITTER				
	USER'S CHOICE	1		2	3
SPECIFIC GRAVITY TRANSMITTER, FLOW-THROUGH TYPE					
USE OF LETTER C AND D DEFINED ON USER'S LEGEND SHEET					

&I

PRIMARY LOCATION **NORMALLY ACCESSIBLE TO OPERATOR	FIELD MOUNTED	AUXILIARY LOCATION ***NORMALLY ACCESSIBLE TO OPERATOR
*  IP1**	2 	3 
	5 	6 
	8 	9 
	11 	12 

the user's needs and the type of symbol and circle size for large diagrams is recommended.



such as IP1 (Instrument Panel #1), CC3 (Computer Console #3), etc., to specify instrument or function

panel devices or functions symbol but with dashed horizontal line



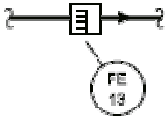
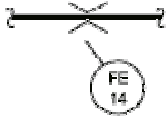
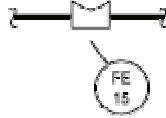
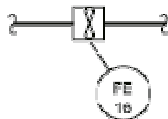
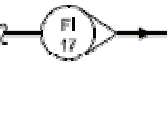
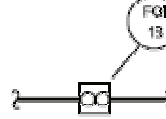

CLASES PARTICULARES, TUTORÍAS TÉCNICAS ONLINE  
 LLAMA O ENVÍA WHATSAPP: 689 45 44 70  
 ---  
 ONLINE PRIVATE LESSONS FOR SCIENCE STUDENTS  
 CALL OR WHATSAPP: 689 45 44 70

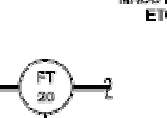
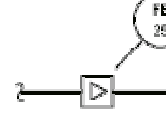
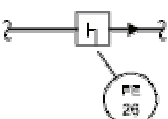
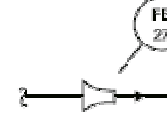
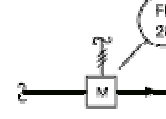
# Representación

10		11		12	
	AVERAGING PITOT TUBE		FLUME		WEIR
13		14		15	
	TURBINE OR PROPELLER-TYPE PRIMARY ELEMENT		VARIABLE AREA FLOW INDICATOR		POSITIVE-DISPLACEMENT-TYPE FLOW TOTALIZING INDICATOR
16		17		18	
	LAMINAR FLOW, ETC.		MASS FLOW ETC		VORTEX SENSOR
19		20		21	
	TARGET TYPE SENSOR		FLOW NOZZLE		MAGNETIC FLOWMETER

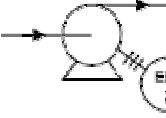
&I

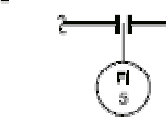
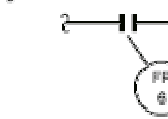
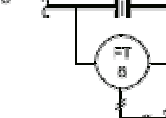
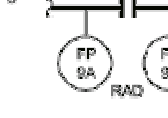
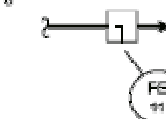
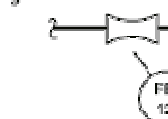
2		3	
	LOW-VOLTAGE SWITCH CONNECTED TO PUMP MOTOR		FLANGE OR CORNER TAP TEST CONNECTIONS WITHOUT ORIFICE PLATE
2		3	
	ORIFICE PLATE WITH FLANGE OR CORNER TAPS CONNECTED TO DIFFERENTIAL-PRESSURE TYPE FLOW INDICATOR		RADIUS TAP TEST CONNECTIONS WITHOUT ORIFICE PLATE
5		6	
	ORIFICE PLATE WITH VENA CONTRACTA, RADIUS, OR PIPE TAPS CONNECTED TO DIFFERENTIAL-PRESSURE TYPE FLOW TRANSMITTER		SINGLE PORT PITOT TUBE OR PITOT-VENTURI TUBE
8		9	
			VENTURI TUBE













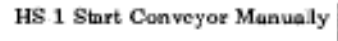

CLASES PARTICULARES, TUTORÍAS TÉCNICAS ONLINE  
 LLAMA O ENVÍA WHATSAPP: 689 45 44 70  
 ---  
 ONLINE PRIVATE LESSONS FOR SCIENCE STUDENTS  
 CALL OR WHATSAPP:689 45 44 70

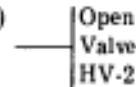

# Representación

## lógicos

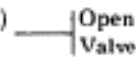

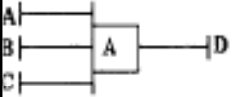
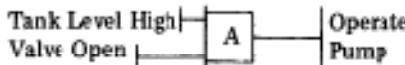
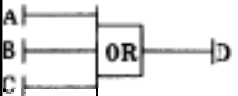
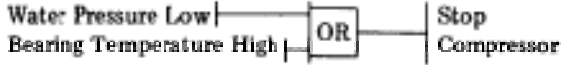

lógicos de control son una forma de representar las acciones implementadas en un rol (P&I) que se desarrollan ante una serie de eventos. Se basan en la lógica.

SYMBOL	DEFINITION	EXAMPLE
<p>Statement of Input </p> <p>Alternatively:   Statement of Input </p> <p>Initiating instrument or device number, if known</p>	An input to the logic sequence	<p>The start position of a hand switch <i>HS-1</i>, is actuated to provide input to start a conveyor.</p> <p>Alternative diagrams:</p> <p>a)  </p> <p>b)  Start Conveyor Manually </p>
<p>Statement of Output </p> <p>Alternatively:   Statement of Output </p> <p>Operated instrument or device number, if known</p>	An output from the logic sequence.	<p>An output from the logic sequence commands valve <i>HV-2</i> to open.</p> <p>Alternative diagrams:</p> <p>a)  </p> <p>b)   </p>
	Logic output <i>D</i> exists if and only if all logic inputs <i>A</i> , <i>B</i> , and <i>C</i> exist.	<p>Operate pump if suction tank level is high and discharge valve is open.</p> 
	Logic output <i>D</i> exists if and only if one or more of logic inputs <i>A</i> , <i>B</i> , and <i>C</i> exist.	<p>Stop compressor if cooling water pressure is low or bearing temperature is high.</p> 

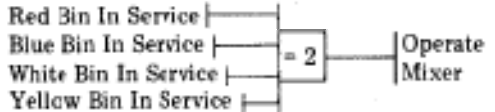

CLASES PARTICULARES, TUTORÍAS TÉCNICAS ONLINE  
 LLAMA O ENVÍA WHATSAPP: 689 45 44 70  
 ---  
 ONLINE PRIVATE LESSONS FOR SCIENCE STUDENTS  
 CALL OR WHATSAPP:689 45 44 70

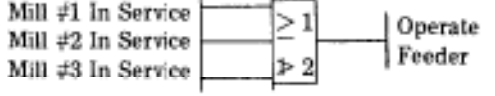

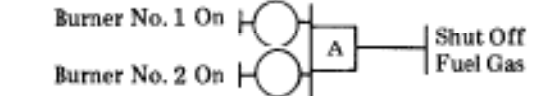
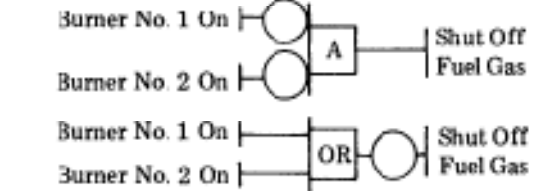
lógicos

SYMBOL	DEFINITION	EXAMPLE
 <p>*Internal details represent numerical quantities (see "Definition").</p>	<p>Logic output <i>D</i> exists if and only if a specified number of logic inputs <i>A</i>, <i>B</i>, and <i>C</i> exist.</p> <p>Mathematical symbols, including the following, shall be used, as appropriate, in specifying the number:</p> <ul style="list-style-type: none"> <li>a. = equal to</li> <li>b. ≠ not equal to</li> <li>c. &lt; less than</li> <li>d. &gt; greater than</li> <li>e. ≥ not less than</li> <li>f. ≤ not greater than</li> <li>g. ≤ less than or equal to [equivalent to <i>f</i>]</li> <li>h. ≥ greater than or equal to [equivalent to <i>e</i>]</li> </ul>	<p>a) Operate mixer if two, and only two, bins are in service.</p> <p>Red Bin In Service Blue Bin In Service White Bin In Service Yellow Bin In Service</p>  <p>b) Stop reaction if at least two safety devices call for stop.</p> <p>Device #1 Actuated Device #2 Actuated Device #3 Actuated Device #4 Actuated Device #5 Actuated</p>  <p>c) Operate materials feeder if at least one and no more than two mills are in service.</p> <p>Mill #1 In Service Mill #2 In Service Mill #3 In Service</p> 
 <p>The <i>NOT</i> symbol may be drawn tangent to an adjacent logic symbol.</p>	<p>Logic output <i>B</i> exists if and only if logic input <i>A</i> does not exist.</p>	<p>Shut off fuel gas if burners no. 1 and no. 2 are not on.</p> <p>Burner No. 1 On Burner No. 2 On</p>  <p>Some Alternatives:</p> 

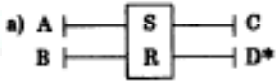
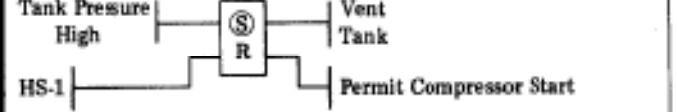
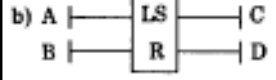
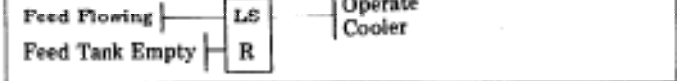

CLASES PARTICULARES, TUTORÍAS TÉCNICAS ONLINE  
 LLAMA O ENVÍA WHATSAPP: 689 45 44 70  
 ONLINE PRIVATE LESSONS FOR SCIENCE STUDENTS  
 CALL OR WHATSAPP: 689 45 44 70

lógicos

SYMBOL	DEFINITION	EXAMPLE
<p>a) </p> <p>*Output D shall not be shown if it is not used.</p>	<p>S represents set memory and R represents reset memory.</p> <p>Logic output C exists as soon as logic input A exists. C continues to exist, regardless of the subsequent state of A, until the memory is reset, i.e., terminated by logic input B existing. C remains terminated regardless of the subsequent state of B, until A causes the memory to be set.</p> <p>Logic output D, if used, exists when C does not exist, and D does not exist when C exists.</p>	<p>If tank pressure becomes high, vent tank and continue venting, regardless of pressure, until venting is stopped by manual actuation of hand switch, HS-1, provided that the pressure is not high. If the venting is stopped, a compressor may be started.</p> <p></p>
	<p><i>Input-Override Option</i> If inputs A and B exist simultaneously, and if it is desired to have A override B, then S should be encircled, i.e., (S) ; if B is to override A, then R should be encircled, i.e., (R)</p> <p><i>Loss-Of-Power-Supply Option</i> The unmodified letter S denotes that no consideration has been given to the action of the memory on loss of the logic power supply. See paragraphs 4.7 b, c, and d, below, and 3.8.</p>	
<p>b) </p> <p>(See Appendix C)</p>	<p>Similar to definition of symbol (a) except that the memory shall be lost in the event of loss of the logic power supply.</p>	<p>If feed begins to flow, the cooler shall operate until the feed tank is empty. In the event of loss of the logic power supply, the cooler shall not operate</p> <p></p>
<p>c) </p>	<p>Similar to definition of symbol (a) except that the memory shall be maintained in the event of loss of the logic power supply.</p>	<p>If standby pump operation is initiated, the pump shall operate, even on loss of the logic power supply, until the process sequence is terminated. The pump shall operate if start and stop commands exist simultaneously.</p> <p></p>



CLASES PARTICULARES, TUTORÍAS TÉCNICAS ONLINE  
 LLAMA O ENVÍA WHATSAPP: 689 45 44 70  
 ---  
 ONLINE PRIVATE LESSONS FOR SCIENCE STUDENTS  
 CALL OR WHATSAPP:689 45 44 70

lógicos

Narrativa de control

Diagrama P&I

Diagrama lógico de control

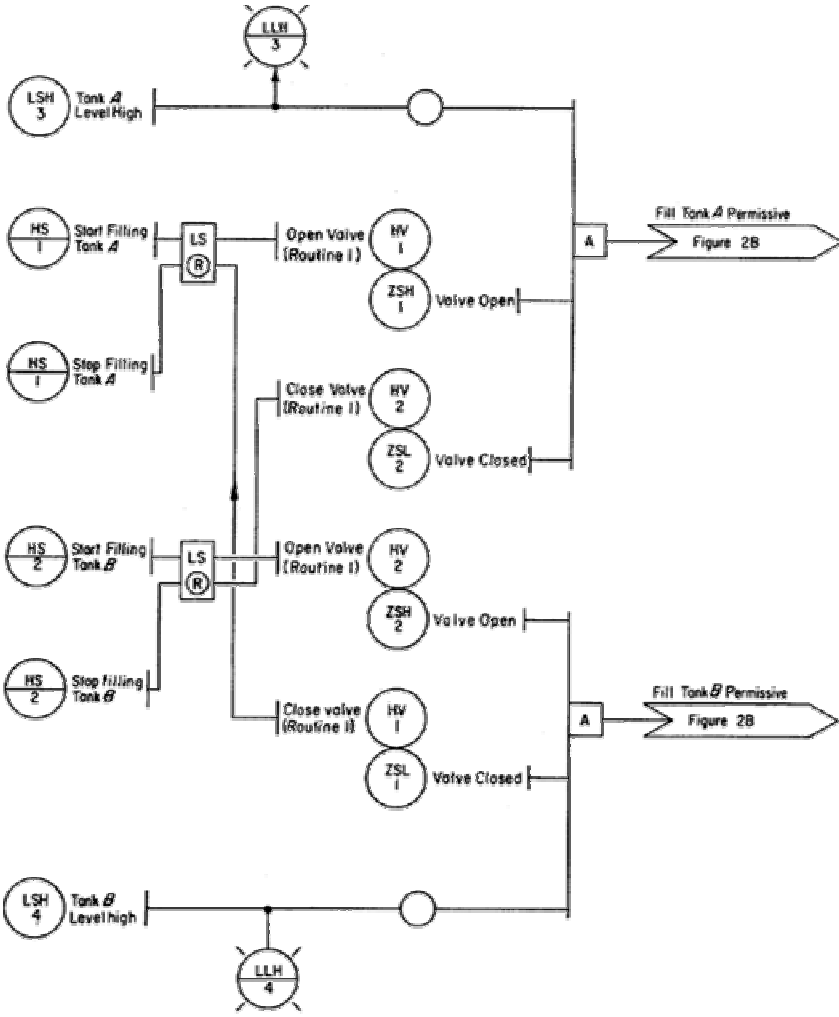
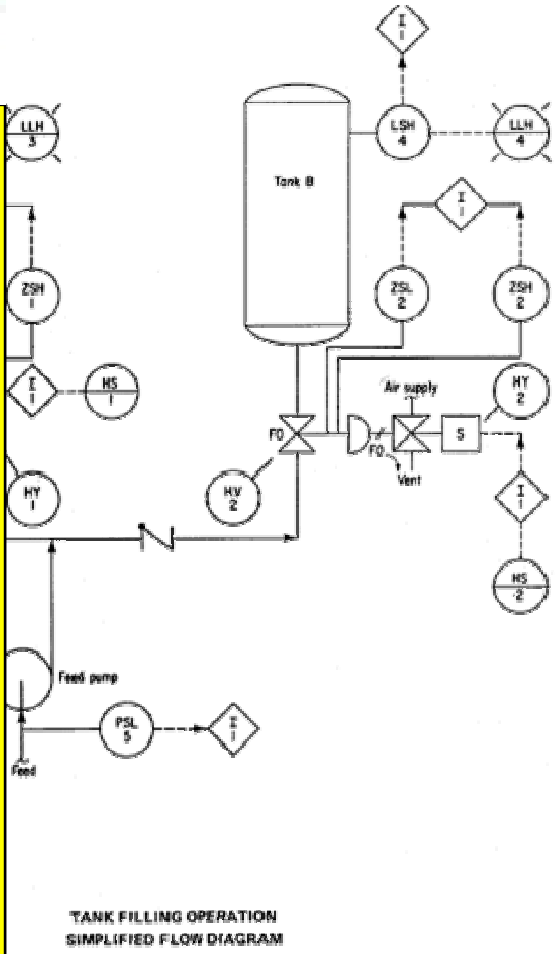

ONLINE PRIVATE LESSONS FOR SCIENCE STUDENTS  
 CALL OR WHATSAPP: 689 45 44 70

CLASES PARTICULARES, TUTORÍAS TÉCNICAS ONLINE  
 LLAMA O ENVIÁ WHATSAPP: 689 45 44 70

Instrumentation Symbols and Identification  
ISA – The instrumentation, systems and  
automation Society

ISA-5.1-1985(R1992). ISBN: 0-87664-844-8

Binary logic diagrams for process operations  
ISA – The instrumentation, systems and  
automation Society

ISA-5.2-1976(R1992). ISBN: 0-87664-331-4



CLASES PARTICULARES, TUTORÍAS TÉCNICAS ONLINE  
LLAMA O ENVÍA WHATSAPP: 689 45 44 70  
--  
ONLINE PRIVATE LESSONS FOR SCIENCE STUDENTS  
CALL OR WHATSAPP:689 45 44 70